

Stereo Plug

17PP004

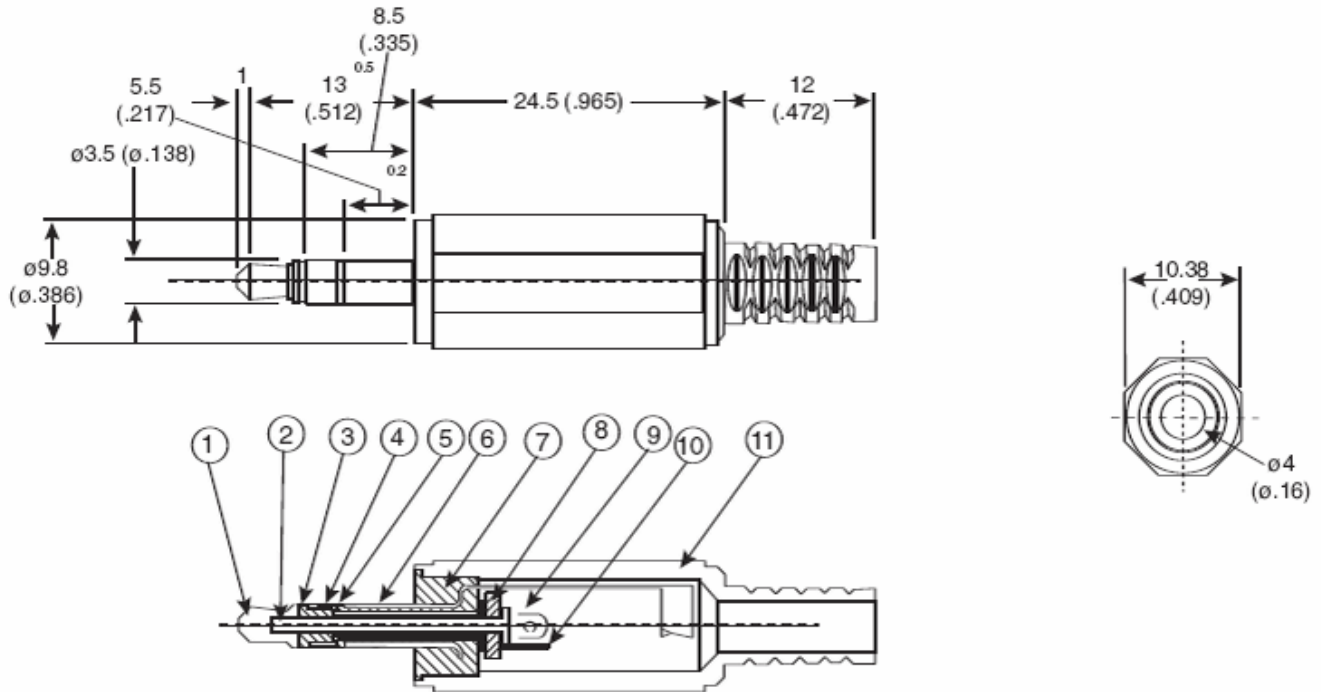

Dimensions: mm (In.)

PIN CONNECTION

No:	1 + 10 (TIP) = LEFT
No:	4 + 9 (RING) = RIGHT
No:	6 (SLEEVE) = GROUND

No	PART NAME	MATERIAL	FINISH
1	Tip	Brass	NI-P
2	Pin	Steel	NI-P
3	Insulator A	POM	---
4	Ring	Brass	NI-P
5	Insulator B	Ebonite	---
6	Sleeve	Brass	NI-P
7	Body	ABS	---
8	Insulator C	PC	---
9	Ring Terminal	Brass	NI-P
10	Tip Terminal	Brass	NI-P
11	Cap	PE	---

SPECIFICATIONS

Plastic threaded stereo phone

Insulation resistance:	100MΩ min. @ 500VDC
Contact resistance:	50mΩ max.
Withstand voltage:	500VAC for 1 minute
Rating:	15VDC 1A
Contacts & terminals:	nickel plated brass
Body:	ABS resin
Cap:	polyethylene
Maximum soldering temperature:	310°C for 2 seconds