

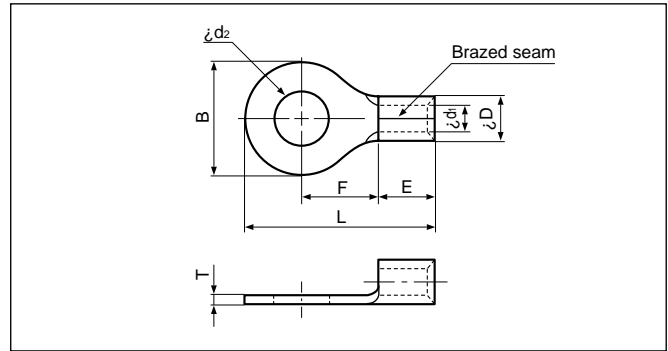

RING TONGUE (R type) Non-insulated



Actual

Refer to page 135 for actual size of the terminal.

File No.: E42024 LR20812 670021

Applicable Wire AWG#(mm ²)	Stud size		Part No.		Standard	Dimensions mm (in.)								Tool No.	Qty/box
	American	Metric	JST	JIS		ød ₂	B	L	F	E	øD	ød ₁	T		
26 to 22 (0.2 to 0.5)	1-2	2	0.5-2			2.2 (.087)	5.2 (.205)	12.4 (.488)	5.8 (.228)	4.0 (.157)	2.0 (.079)	1.0 (.039)	0.5 (.020)	YHT-2622 YA-1 YA-2 BCT-0514	1,000
	3-4	3	0.5-3			3.2 (.126)	5.2 (.205)	12.4 (.488)	5.8 (.228)						
	5-6	3.5	0.5-3.7			3.7 (.146)	6.6 (.260)	15.0 (.591)	7.7 (.303)						
	8	4	0.5-4			4.3 (.169)	6.6 (.260)	15.0 (.591)	7.7 (.303)						
	10	5	0.5-5			5.3 (.209)	8.0 (.315)	15.0 (.591)	7.0 (.276)						
22 to 16 (0.25 to 1.65)	1-2	2	1.25-2			2.2 (.087)	5.5 (.217)	11.5 (.453)	4.0 (.157)	4.8 (.189)	3.4 (.134)	1.7 (.067)	0.8 (.031)	YHT-2210 YA-1 YA-2 YA-4 BCT-0514	1,000
	3-4	3	1.25-3	R1.25-3		3.2 (.126)	5.5 (.217)	11.5 (.453)	4.0 (.157)						
	3-4	3	1.25-MS3			3.2 (.126)	5.5 (.217)	13.2 (.520)	5.6 (.220)						
	3-4	3	1.25-M3.3			3.2 (.126)	6.6 (.260)	14.4 (.567)	6.3 (.248)						
	3-4	3	1.25-L3			3.2 (.126)	8.0 (.315)	15.8 (.622)	7.0 (.276)						
	5-6	3.5	1.25-3.7			3.7 (.146)	5.5 (.217)	11.5 (.453)	4.0 (.157)						
	5-6	3.5	1.25-M3	R1.25-3.5		3.7 (.146)	6.6 (.260)	14.4 (.567)	6.3 (.248)						
	5-6	3.5	1.25-L3.7			3.7 (.146)	8.0 (.315)	15.8 (.622)	7.0 (.276)						
	8	4	1.25-M4			4.3 (.169)	6.6 (.260)	14.4 (.567)	6.3 (.248)						
	8	4	1.25-4	R1.25-4		4.3 (.169)	8.0 (.315)	15.8 (.622)	7.0 (.276)						
	10	5	1.25-5	R1.25-5		5.3 (.209)	8.0 (.315)	15.8 (.622)	7.0 (.276)						
	10	5	1.25-5NS			5.3 (.209)	9.0 (.354)	20.4 (.803)	11.1 (.437)						
	10	5	1.25-L5			5.3 (.209)	11.6 (.457)	21.7 (.854)	11.1 (.437)						
	1/4	6	1.25-6			6.4 (.252)	11.6 (.457)	21.7 (.854)	11.1 (.437)						
	5/16	8	1.25-8			8.4 (.331)	11.6 (.457)	21.7 (.854)	11.1 (.437)						
	3/8	9	1.25-9			9.8 (.386)	13.6 (.535)	25.5 (1.004)	13.9 (.547)						
	3/8	10	1.25-10			10.5 (.413)	13.6 (.535)	25.5 (1.004)	13.9 (.547)						
1/2	12	1.25-12			13.0 (.512)	19.0 (.748)	31.0 (1.220)	16.7 (.657)							
16 to 14 (1.04 to 2.63)	1-2	2	2-S2			2.2 (.087)	6.4 (.252)	12.3 (.484)	4.3 (.169)	4.8 (.189)	4.1 (.161)	2.3 (.091)	0.8 (.031)	YHT-2210 YA-1 YA-2 YA-4 BCT-0514	1,000
	3-4	3	2-MS3			3.2 (.126)	5.5 (.217)	13.2 (.520)	5.6 (.220)						
	3-4	3	2-S3.3			3.2 (.126)	6.4 (.252)	12.3 (.484)	4.3 (.169)						
	3-4	3	2-M3.3			3.2 (.126)	6.6 (.260)	14.4 (.567)	6.3 (.248)						
	3-4	3	2-3			3.2 (.126)	8.5 (.335)	16.8 (.661)	7.8 (.307)						
	5-6	3.5	2-S3			3.7 (.146)	6.4 (.252)	12.3 (.484)	4.3 (.169)						
	5-6	3.5	2-M3	R2-3.5		3.7 (.146)	6.6 (.260)	14.4 (.567)	6.3 (.248)						
	5-6	3.5	2-P3.5			3.7 (.146)	7.0 (.276)	16.0 (.630)	7.7 (.303)						
	5-6	3.5	2-3.7			3.7 (.146)	8.5 (.335)	16.8 (.661)	7.8 (.307)						
	8	4	2-M4			4.3 (.169)	6.6 (.260)	14.4 (.567)	6.3 (.248)						
	8	4	2-P4			4.3 (.169)	7.0 (.276)	16.0 (.630)	7.7 (.303)						
	8	4	2-4	R2-4		4.3 (.169)	8.5 (.335)	16.8 (.661)	7.8 (.307)						
	10	5	2-M5			5.3 (.209)	8.5 (.335)	16.8 (.661)	7.8 (.307)						
	10	5	2-5NS			5.3 (.209)	9.0 (.354)	20.3 (.799)	11.0 (.433)						
	10	5	2-5	R2-5		5.3 (.209)	9.5 (.374)	16.8 (.661)	7.3 (.287)						
	1/4	6	2-6	R2-6		6.4 (.252)	12.0 (.472)	21.8 (.858)	11.0 (.433)						
	5/16	8	2-8	R2-8		8.4 (.331)	12.0 (.472)	21.8 (.858)	11.0 (.433)						
	3/8	9	2-9			9.8 (.386)	13.6 (.535)	25.5 (1.004)	13.9 (.547)						
	3/8	10	2-10			10.5 (.413)	13.6 (.535)	25.5 (1.004)	13.9 (.547)						
	1/2	12	2-12			13.0 (.512)	19.0 (.748)	31.0 (1.220)	16.7 (.675)						
1/2	14	2-14			15.0 (.591)	27.0 (1.063)	39.5 (1.555)	21.2 (.835)							
5/8	16	2-16			17.0 (.669)	27.0 (1.063)	39.5 (1.555)	21.2 (.835)							
3/4	20	2-20			21.0 (.827)	27.0 (1.063)	39.5 (1.555)	21.2 (.835)							

Note:1) Products with the JIS mark conform to JIS C2805.

2) The part numbers indicated in the above table are for products with a brazed seam.

When ordering products with a nominal size of 0.5 to 5.5 with a butted seam, add the prefix "WS" to the part number (ex.2-4 → **WS2-4**).

3) Delivery lead times may vary depending on the product. Contact JST for details.

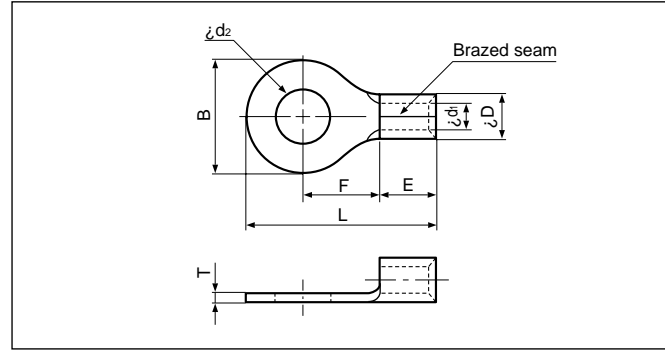
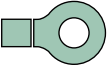

Actual
 Refer to page 135 for
 actual size of the terminal.

Applicable Wire AWG#(mm ²)	Stud size		Part No.		Standard	Dimensions mm (in.)								Tool No.	Qty/box
	American	Metric	JST	JIS		ϕd_2	B	L	F	E	ϕD	ϕd_1	T		
14 to 12 (3.5)	3-4	3	3.5-R3		UL	3.2 (.126)	8.0 (.315)	17.8 (.707)	9.0 (.354)	4.8 (.189)	4.8 (.189)	2.7 (.106)	1.0 (.039)	YHT-2210 (Dies mark. 5) BCT-0514	1,000
	8	4	3.5-R4		UL	4.3 (.169)	8.0 (.315)	17.8 (.707)	9.0 (.354)						
	8	4	3.5-4		UL	4.3 (.169)	10.3 (.406)	18.6 (.732)	8.6 (.339)						
	10	5	3.5-R5		UL	5.3 (.209)	8.0 (.315)	17.8 (.707)	9.0 (.354)						
	10	5	3.5-5		UL	5.3 (.209)	10.3 (.406)	18.6 (.732)	8.6 (.339)						
12 to 10 (2.63 to 6.64)	3-4	3	5.5-S3.3		UL	3.2 (.126)	7.2 (.283)	15.7 (.618)	5.9 (.232)	6.8 (.268)	5.6 (.220)	3.4 (.134)	1.0 (.039)	YHT-2210 YA-1 YA-2 YA-4 BCT-0514	1,000
	3-4	3	5.5-3		UL	3.2 (.126)	9.5 (.374)	19.8 (.780)	8.3 (.327)						
	5-6	3.5	5.5-S3		UL	3.7 (.146)	7.2 (.283)	15.7 (.618)	5.9 (.232)						
	5-6	3.5	5.5-3.7		UL	3.7 (.146)	9.5 (.374)	19.8 (.780)	8.3 (.327)						
	8	4	5.5-S4		UL	4.3 (.169)	7.2 (.283)	15.7 (.618)	5.9 (.232)						
	8	4	5.5-4NS		UL	4.3 (.169)	8.0 (.315)	19.1 (.752)	8.3 (.327)						
	8	4	5.5-4	R5.5-4	UL	4.3 (.169)	9.5 (.374)	19.8 (.780)	8.3 (.327)						
	10	5	5.5-5NS		UL	5.3 (.209)	8.0 (.315)	19.1 (.752)	8.3 (.327)						
	10	5	5.5-5	R5.5-5	UL	5.3 (.209)	9.5 (.374)	19.8 (.780)	8.3 (.327)						
	10	5	5.5-S5		UL	5.3 (.209)	13.2 (.520)	22.4 (.882)	9.0 (.354)						
	1/4	6	5.5-6NS		UL	6.4 (.252)	9.0 (.354)	24.3 (.957)	13.0 (.512)						
	1/4	6	5.5-6	R5.5-6	UL	6.4 (.252)	12.0 (.472)	25.8 (1.016)	13.0 (.512)						
	1/4	6	5.5-S6		UL	6.4 (.252)	13.2 (.520)	22.4 (.882)	9.0 (.354)						
	1/4	6	5.5-L6		UL	6.4 (.252)	15.0 (.591)	28.0 (1.102)	13.7 (.539)						
	5/16	8	5.5-S8		UL	8.4 (.331)	13.2 (.520)	22.4 (.882)	9.0 (.354)						
	5/16	8	5.5-8	R5.5-8	UL	8.4 (.331)	15.0 (.591)	28.0 (1.102)	13.7 (.539)						
	3/8	9	5.5-9		UL	9.8 (.386)	15.0 (.591)	28.0 (1.102)	13.7 (.539)						
	3/8	10	5.5-10	R5.5-10	UL	10.5 (.413)	15.0 (.591)	28.0 (1.102)	13.7 (.539)						
	3/8	10	5.5-L10		UL	10.5 (.413)	19.2 (.756)	32.4 (1.276)	16.0 (.630)						
	7/16	12	5.5-12		UL	13.0 (.512)	19.2 (.756)	32.4 (1.276)	16.0 (.630)						
1/2	14	5.5-14		UL	15.0 (.591)	32.0 (1.260)	48.1 (1.894)	25.3 (.996)							
5/8	16	5.5-16		UL	17.0 (.669)	32.0 (1.260)	48.1 (1.894)	25.3 (.996)							
11/16	18	5.5-18		UL	19.0 (.748)	32.0 (1.260)	48.1 (1.894)	25.3 (.996)							
3/4	20	5.5-20		UL	21.0 (.827)	32.0 (1.260)	48.1 (1.894)	25.3 (.996)							

Note:1) Products with the JIS mark conform to JIS C2805.

2) The part numbers indicated in the above table are for products with a brazed seam.

When ordering products with a nominal size of 0.5 to 5.5 with a butted seam, add the prefix "WS" to the part number (ex.5.5-4 → **WS5.5-4**).

3) Delivery lead times may vary depending on the product. Contact JST for details.



RING TONGUE (R type) Non-insulated



Actual

Refer to page 135 to 136 for actual size of the terminal.

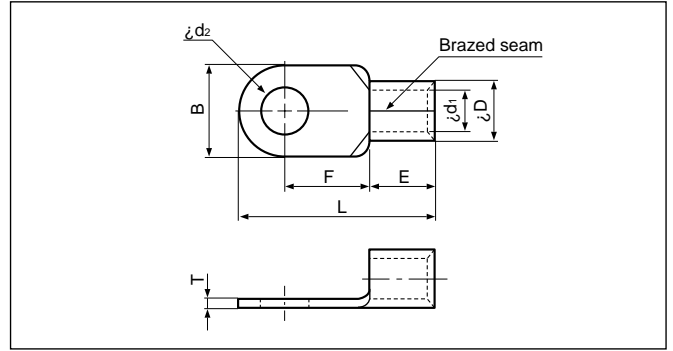

Applicable Wire AWG#(mm ²)	Stud size		Part No.		Standard	Dimensions mm (in.)							Tool No.	Qty/box	
	American	Metric	JST	JIS		ϕd_2	B	L	F	E	ϕD	ϕd_1			T
8 (6.64 to 10.52)	8	4	8-NK4		UL Ⓢ	4.3 (.169)	9.0 (.354)	16.5 (.650)	5.8 (.228)	6.2 (.244)	7.1 (.280)	4.5 (.177)	1.2 (.047)	YHT-8S YA-4 YPT-60-21 YF-1 YET-60-1 E-4 (Note 2)	500
	8	4	8-4NS		UL	4.3 (.169)	8.0 (.315)	21.8 (.858)	9.3 (.366)	8.5 (.335)				YHT-8S YA-4, YA-5 YPT-60-21 YPT-150-1 BCT-0514 BCT-860 BCT-8150 YF-1 YET-60-1 E-4 YET-150-1	100
	8	4	8-4		UL Ⓢ	4.3 (.169)	12.0 (.472)	23.8 (.937)	9.3 (.366)	8.5 (.335)				YHT-8S YA-4 YPT-60-21 YF-1 YET-60-1 E-4 (Note 2)	500
	10	5	8-NK5		UL	5.3 (.209)	9.0 (.354)	16.5 (.650)	5.8 (.228)	6.2 (.244)				YHT-8S YA-4 YPT-60-21 YF-1 YET-60-1 E-4 (Note 2)	500
	10	5	8-5NS		UL	5.3 (.209)	9.0 (.354)	22.3 (.878)	9.3 (.366)	8.5 (.335)				100	
	10	5	8-5	R8-5	UL Ⓢ Ⓢ	5.3 (.209)	12.0 (.472)	23.8 (.937)	9.3 (.366)					500	
	10	5	8-L5NS		UL	5.3 (.209)	9.0 (.354)	26.8 (1.055)	13.8 (.543)					100	
	10	5	8-L5		UL Ⓢ	5.3 (.209)	15.0 (.591)	29.8 (1.173)	13.8 (.543)					500	
	1/4	6	8-6NS		UL	6.4 (.252)	9.6 (.378)	22.6 (.890)	9.3 (.366)					100	
	1/4	6	8-6	R8-6	UL Ⓢ Ⓢ	6.4 (.252)	12.0 (.472)	23.8 (.937)	9.3 (.366)					500	
	1/4	6	8-L6		UL Ⓢ	6.4 (.252)	15.0 (.591)	29.8 (1.173)	13.8 (.543)					100	
	5/16	8	8-8NS		UL	8.4 (.331)	11.5 (.453)	28.1 (1.106)	13.8 (.543)					500	
	5/16	8	8-8	R8-8	UL Ⓢ Ⓢ	8.4 (.331)	15.0 (.591)	29.8 (1.173)	13.8 (.543)					100	
	3/8	9	8-9		UL Ⓢ	9.8 (.386)	15.0 (.591)	29.8 (1.173)	13.8 (.543)					500	
	3/8	10	8-10	R8-10	UL Ⓢ Ⓢ	10.5 (.413)	15.0 (.591)	29.8 (1.173)	13.8 (.543)					500	
	3/8	10	8-L10			10.5 (.413)	20.0 (.787)	33.5 (1.319)	15.0 (.591)					100	
	7/16	11	8-11		UL Ⓢ	11.5 (.453)	20.0 (.787)	33.5 (1.319)	15.0 (.591)					500	
	7/16	12	8-12		UL Ⓢ	13.0 (.512)	20.0 (.787)	33.5 (1.319)	15.0 (.591)					100	
	1/2	14	8-14		UL Ⓢ	15.0 (.591)	31.6 (1.244)	50.0 (1.969)	25.7 (1.012)					500	
	5/8	16	8-16		UL Ⓢ	17.0 (.669)	31.6 (1.244)	50.0 (1.969)	25.7 (1.012)					100	
11/16	18	8-18		UL Ⓢ	19.0 (.748)	31.6 (1.244)	50.0 (1.969)	25.7 (1.012)	500						
3/4	20	8-20		UL Ⓢ	21.0 (.827)	31.6 (1.244)	50.0 (1.969)	25.7 (1.012)	200						

Note:1) Products with the JIS mark Ⓢ conform to JIS C2805.

2) Please use the die AD-901S for the pneumatic tool YA-4, and the die 8NK-6 for the hydraulic tools YPT-60-21/YET-60-1.

3) Delivery lead times may vary depending on the product. Contact JST for details.

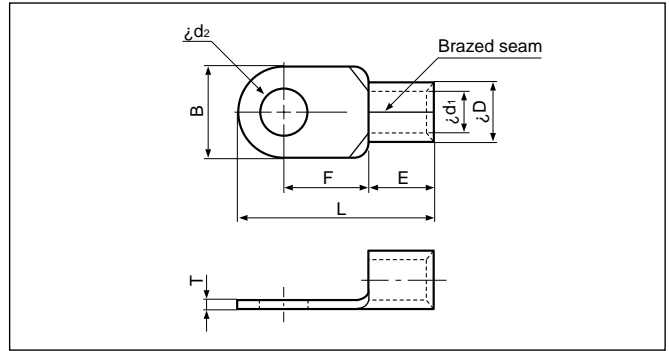

Actual
 Refer to page 136 for
 actual size of the terminal.

Applicable Wire AWG#(mm ²)	Stud size		Part No.		Standard	Dimensions mm (in.)							Tool No.	Qty/box		
	American	Metric	JST	JIS		ϕd_2	B	L	F	E	ϕD	ϕd_1			T	
6 (10.52 to 16.78)	8	4	14-4		UL	4.3 (.169)	12.0 (.472)	29.8(1.173)	13.3 (.524)	10.5 (.413)	9.0 (.354)	5.8 (.228)	1.5 (.059)	YA-4 YA-5 YPT-60-21 YPT-150-1 BCT-0514 BCT-860 BCT-8150 YF-1 YET-60-1 E-4 YET-150-1	200	
	8	4	14-NK4			4.3 (.169)	12.2 (.480)	23.0 (.906)	7.7 (.303)	9.2 (.362)						
	10	5	14-5NS		UL	5.3 (.209)	9.0 (.354)	28.3(1.114)	13.3 (.524)	10.5 (.413)					100	
	10	5	14-5	R14-5	UL SC	5.3 (.209)	12.0 (.472)	29.8(1.173)	13.3 (.524)							
	10	5	14-NK5		UL SC	5.3 (.209)	12.2 (.480)	23.0 (.906)	7.7 (.303)	9.2 (.362)					200	
	1/4	6	14-6NS		UL	6.4 (.252)	9.6 (.378)	28.6(1.126)	13.3 (.524)							
	1/4	6	14-6	R14-6	UL SC	6.4 (.252)	12.0 (.472)	29.8(1.173)	13.3 (.524)	100						
	1/4	6	14-L6		UL	6.4 (.252)	16.0 (.630)	32.8(1.291)	14.5 (.571)							
	5/16	8	14-8NS		UL	8.4 (.331)	11.5 (.453)	30.8(1.213)	14.5 (.571)	10.5 (.413)					100	
	5/16	8	14-S8		UL	8.4 (.331)	12.0 (.472)	31.0(1.220)	14.5 (.571)							
	5/16	8	14-8	R14-8	UL SC	8.4 (.331)	16.0 (.630)	32.8(1.291)	14.5 (.571)							
	3/8	9	14-9		UL SC	9.8 (.386)	16.0 (.630)	32.8(1.291)	14.5 (.571)							
	3/8	10	14-10	R14-10	UL SC	10.5 (.413)	16.0 (.630)	32.8(1.291)	14.5 (.571)							
	3/8	10	14-L10		UL SC	10.5 (.413)	22.0 (.866)	41.0(1.614)	19.5 (.739)							
	7/16	11	14-11		UL SC	11.5 (.453)	22.0 (.866)	41.0(1.614)	19.5 (.739)							
	7/16	12	14-12	R14-12	UL SC	13.0 (.512)	22.0 (.866)	41.0(1.614)	19.5 (.739)							
	1/2	14	14-14	R14-14	UL SC	15.0 (.591)	30.0(1.181)	49.0(1.929)	23.5 (.925)							
5/8	16	14-16		UL SC	17.0 (.669)	31.6(1.244)	51.5(2.028)	25.2 (.992)								
11/16	18	14-18		UL SC	19.0 (.748)	31.6(1.244)	51.5(2.028)	25.2 (.992)								
3/4	20	14-20		UL SC	21.0 (.827)	31.6(1.244)	51.5(2.028)	25.2 (.992)								
4 (16.78 to 26.66)	10	5	22-5NS		UL	5.3 (.209)	9.5 (.374)	28.7(1.130)	12.0 (.472)	12.0 (.472)	11.5 (.453)	7.7 (.303)	1.8 (.071)	YA-5 YPT-60-21 YPT-150-1 BCT-860 BCT-8150 YF-1 YET-60-1 E-4 YET-150-1		100
	10	5	22-S5		UL	5.3 (.209)	12.0 (.472)	30.0(1.181)	12.0 (.472)							
	10	5	22-5		UL SC	5.3 (.209)	16.5 (.650)	33.7(1.327)	13.5 (.531)							
	1/4	6	22-S6		UL SC	6.4 (.252)	12.0 (.472)	30.0(1.181)	12.0 (.472)							
	1/4	6	22-6	R22-6	UL SC	6.4 (.252)	16.5 (.650)	33.7(1.327)	13.5 (.531)							
	5/16	8	22-S8		UL SC	8.4 (.331)	12.0 (.427)	30.0(1.181)	12.0 (.472)							
	5/16	8	22-8	R22-8	UL SC	8.4 (.331)	16.5 (.650)	33.7(1.327)	13.5 (.531)							
	3/8	9	22-9		UL SC	9.8 (.386)	17.5 (.689)	36.7(1.445)	16.0 (.630)							
	3/8	10	22-S10		UL	10.5 (.413)	16.5 (.650)	33.7(1.327)	13.5 (.531)							
	3/8	10	22-10	R22-10	UL SC	10.5 (.413)	17.5 (.689)	36.7(1.445)	16.0 (.630)							
	7/16	11	22-11		UL SC	11.5 (.453)	22.0 (.866)	42.5(1.673)	19.5 (.768)							
	7/16	12	22-12	R22-12	UL SC	13.0 (.512)	22.0 (.866)	42.5(1.673)	19.5 (.768)							
	1/2	14	22-14	R22-14	UL SC	15.0 (.591)	30.0(1.181)	51.5(2.028)	24.5 (.965)							
	5/8	16	22-16		UL SC	17.0 (.669)	30.0(1.181)	51.5(2.028)	24.5 (.965)							
	11/16	18	22-18		UL SC	19.0 (.748)	30.0(1.181)	51.5(2.028)	24.5 (.965)							
3/4	20	22-20		UL SC	21.0 (.827)	30.0(1.181)	51.5(2.028)	24.5 (.965)								

Note:1) Products with the JIS mark conform to JIS C2805.
 2) Delivery lead times may vary depending on the product. Contact JST for details.

Actual
Refer to page 137 for
actual size of the terminal.
(except for 38-S9)



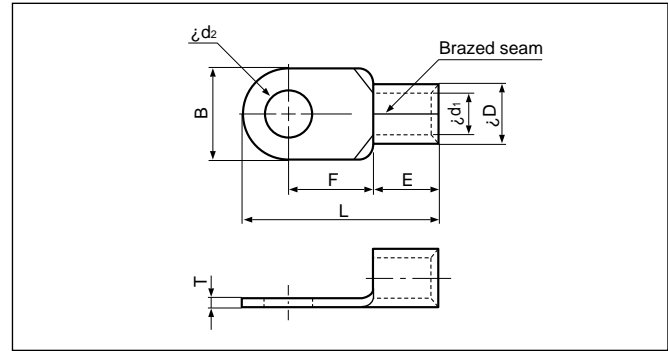
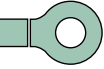

Actual
 Refer to page 137 to 138 for actual size of the terminal.

Applicable Wire AWG#(mm ²)	Stud size		Part No.		Standard	Dimensions mm (in.)								Tool No.	Qty/box
	American	Metric	JST	JIS		ød ₂	B	L	F	E	øD	ød ₁	T		
3/0 (76.28 to 96.3)	-	-	80-S0			-	27.0(1.063)	54.2(2.134)	20.7 (.815)	20.0 (.787)	19.5 (.768)	14.5 (.571)	2.3 (.091)	YPT-150-1 BCT-8150 YF-1 YET-150-1 E-4 YET-300-1 YET-300N	25
	-	-	80-L0			-	32.0(1.260)	68.0(2.677)	32.0 (1.260)						
	1/4	6	80-6		UL Ⓢ	6.4 (.252)	27.0(1.063)	54.2(2.134)	20.7 (.815)						
	5/16	8	80-8		UL Ⓢ	8.4 (.331)	27.0(1.063)	54.2(2.134)	20.7 (.815)						
	5/16	8	80-L8		UL Ⓢ	8.4 (.331)	32.0(1.260)	68.0(2.677)	32.0 (1.260)						
	3/8	9	80-9		UL Ⓢ	9.8 (.386)	27.0(1.063)	54.2(2.134)	20.7 (.815)						
	3/8	10	80-10	R80-10	UL Ⓢ Ⓢ	10.5 (.413)	27.0(1.063)	54.2(2.134)	20.7 (.815)						
	3/8	10	80-L10		UL Ⓢ	10.5 (.413)	32.0(1.260)	68.0(2.677)	32.0 (1.260)						
	7/16	11	80-11		UL Ⓢ	11.5 (.453)	27.0(1.063)	54.2(2.134)	20.7 (.815)						
	7/16	12	80-12	R80-12	UL Ⓢ Ⓢ	13.0 (.512)	27.0(1.063)	54.2(2.134)	20.7 (.815)						
	7/16	12	80-L12		UL Ⓢ	13.0 (.512)	32.0(1.260)	68.0(2.677)	32.0 (1.260)						
	1/2	14	80-14	R80-14	UL Ⓢ Ⓢ	15.0 (.591)	32.0(1.260)	68.0(2.677)	32.0 (1.260)						
	5/8	16	80-16	R80-16	UL Ⓢ Ⓢ	17.0 (.669)	32.0(1.260)	68.0(2.677)	32.0 (1.260)						
	11/16	18	80-18		UL Ⓢ	19.0 (.748)	32.0(1.260)	68.0(2.677)	32.0 (1.260)						
3/4	20	80-20		UL Ⓢ	21.0 (.827)	32.0(1.260)	68.0(2.677)	32.0 (1.260)							
7/8	22	80-22		UL Ⓢ	23.0 (.906)	32.0(1.260)	68.0(2.677)	32.0 (1.260)							
4/0 (96.3 to 117.2)	-	-	100-S0			-	28.5(1.122)	55.6(2.189)	20.4 (.803)	21.0 (.827)	22.3 (.878)	16.4 (.646)	2.6 (.102)	YPT-150-1 BCT-8150 YF-1 YET-150-1 E-4 YET-300-1 YET-300N	25
	-	-	100-L0			-	32.0(1.260)	69.0(2.717)	32.0 (1.260)						
	1/4	6	100-6		UL Ⓢ	6.4 (.252)	28.5(1.122)	55.6(2.189)	20.4 (.803)						
	5/16	8	100-8		UL Ⓢ	8.4 (.331)	28.5(1.122)	55.6(2.189)	20.4 (.803)						
	5/16	8	100-L8		UL Ⓢ	8.4 (.331)	32.0(1.260)	69.0(2.717)	32.0 (1.260)						
	3/8	9	100-9		UL Ⓢ	9.8 (.386)	28.5(1.122)	55.6(2.189)	20.4 (.803)						
	3/8	10	100-10	R100-10	UL Ⓢ Ⓢ	10.5 (.413)	28.5(1.122)	55.6(2.189)	20.4 (.803)						
	3/8	10	100-L10		UL Ⓢ	10.5 (.413)	32.0(1.260)	69.0(2.717)	32.0 (1.260)						
	7/16	11	100-11		UL Ⓢ	11.5 (.453)	28.5(1.122)	55.6(2.189)	20.4 (.803)						
	7/16	12	100-12	R100-12	UL Ⓢ Ⓢ	13.0 (.512)	28.5(1.122)	55.6(2.189)	20.4 (.803)						
	7/16	12	100-L12		UL Ⓢ	13.0 (.512)	32.0(1.260)	69.0(2.717)	32.0 (1.260)						
	1/2	14	100-14	R100-14	UL Ⓢ Ⓢ	15.0 (.591)	32.0(1.260)	69.0(2.717)	32.0 (1.260)						
	5/8	16	100-16	R100-16	UL Ⓢ Ⓢ	17.0 (.669)	32.0(1.260)	69.0(2.717)	32.0 (1.260)						
	11/16	18	100-18	R100-18	UL Ⓢ Ⓢ	19.0 (.748)	32.0(1.260)	69.0(2.717)	32.0 (1.260)						
3/4	20	100-20	R100-20	UL Ⓢ Ⓢ	21.0 (.827)	32.0(1.260)	69.0(2.717)	32.0 (1.260)							
7/8	22	100-22		UL Ⓢ	23.0 (.906)	32.0(1.260)	69.0(2.717)	32.0 (1.260)							

Note: 1) Products with the JIS mark Ⓢ conform to JIS C2805.
 2) Part numbers containing "S0" or "L0" do not have stud holes.
 3) Delivery lead times may vary depending on the product. Contact JST for details.



RING TONGUE (R type) Non-insulated



Actual

Refer to page 138 for actual size of the terminal.

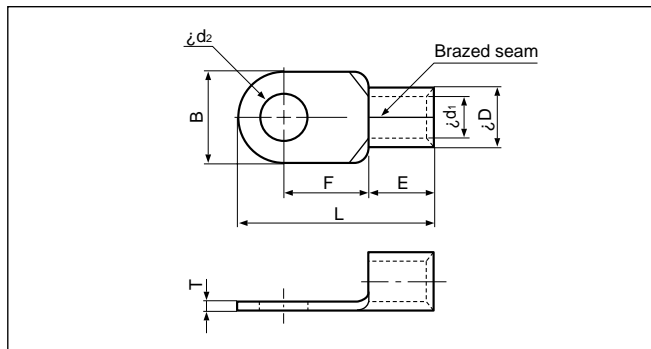

Applicable Wire AWG#(mm ²)	Stud size		Part No.	Standard	Dimensions mm (in.)								Tool No.	Qty/box
	American	Metric			ød ₂	B	L	F	E	øD	ød ₁	T		
250/300 (117.2 to 152.05)	-	-	150-S0		-	36.0(1.417)	66.0(2.600)	23.0 (.906)	27.0 (1.063)	26.5 (1.043)	19.5 (.768)	3.2 (.126)	YPT-150-1 BCT-8150 YF-1 YET-150-1 E-4 YET-300-1 YET-300N	20
	-	-	150-L0		-	36.0(1.417)	81.0(3.189)	36.0 (1.417)						
	1/4	6	150-6	UL Ⓢ	6.4 (.252)	36.0(1.417)	66.0(2.600)	23.0 (.906)						
	5/16	8	150-8	UL Ⓢ	8.4 (.331)	36.0(1.417)	66.0(2.600)	23.0 (.906)						
	5/16	8	150-L8	UL Ⓢ	8.4 (.331)	36.0(1.417)	81.0(3.189)	36.0 (1.417)						
	3/8	9	150-9	UL Ⓢ	9.8 (.386)	36.0(1.417)	66.0(2.600)	23.0 (.906)						
	3/8	10	R150-10	UL Ⓢ Ⓢ	10.5 (.413)	36.0(1.417)	66.0(2.600)	21.0 (.827)						
	3/8	10	150-10	UL Ⓢ	10.5 (.413)	36.0(1.417)	66.0(2.600)	23.0 (.906)						
	3/8	10	150-L10	UL Ⓢ	10.5 (.413)	36.0(1.417)	81.0(3.189)	36.0 (1.417)						
	7/16	11	150-11	UL Ⓢ	11.5 (.453)	36.0(1.417)	66.0(2.600)	23.0 (.906)						
	7/16	12	R150-12	UL Ⓢ Ⓢ	13.0 (.512)	36.0(1.417)	66.0(2.600)	21.0 (.827)						
	7/16	12	150-12	UL Ⓢ	13.0 (.512)	36.0(1.417)	66.0(2.600)	23.0 (.906)						
	7/16	12	150-L12	UL Ⓢ	13.0 (.512)	36.0(1.417)	81.0(3.189)	36.0 (1.417)						
	1/2	14	R150-14	UL Ⓢ Ⓢ	15.0 (.591)	36.0(1.417)	68.0(2.677)	23.0 (.906)						
	5/8	16	150-16	UL Ⓢ	17.0 (.669)	36.0(1.417)	66.0(2.600)	23.0 (.906)						
	5/8	16	R150-16	UL Ⓢ Ⓢ	17.0 (.669)	36.0(1.417)	68.0(2.677)	23.0 (.906)						
	5/8	16	150-L16	UL Ⓢ	17.0 (.669)	36.0(1.417)	81.0(3.189)	36.0 (1.417)						
	11/16	18	R150-18	UL Ⓢ Ⓢ	19.0 (.748)	36.0(1.417)	81.0(3.189)	36.0 (1.417)						
3/4	20	R150-20	UL Ⓢ Ⓢ	21.0 (.827)	36.0(1.417)	81.0(3.189)	36.0 (1.417)							
7/8	22	150-22	UL Ⓢ	23.0 (.906)	36.0(1.417)	81.0(3.189)	36.0 (1.417)							
15/16	24	150-24	UL Ⓢ	25.0 (.984)	36.0(1.417)	81.0(3.189)	36.0 (1.417)							
1	27	150-27	UL Ⓢ	28.0 (1.102)	36.0(1.417)	81.0(3.189)	36.0 (1.417)							
350 (152.05 to 192.60)	-	-	180-S0		-	38.5(1.516)	69.0(2.717)	24.5 (.965)	28.5 (1.122)	28.5 (1.122)	21.0 (.827)	3.5 (.138)	YF-1 YET-300-1 E-4 YET-300N	20
	-	-	180-L0		-	38.5(1.516)	86.8(3.417)	39.0 (1.535)						
	5/16	8	180-8	UL Ⓢ	8.4 (.331)	38.5(1.516)	69.0(2.717)	24.5 (.965)						
	5/16	8	180-L8	UL Ⓢ	8.4 (.331)	38.5(1.516)	86.8(3.417)	39.0 (1.535)						
	3/8	10	180-10	UL Ⓢ	10.5 (.413)	38.5(1.516)	69.0(2.717)	24.5 (.965)						
	3/8	10	180-L10	UL Ⓢ	10.5 (.413)	38.5(1.516)	86.8(3.417)	39.0 (1.535)						
	7/16	11	180-11	UL Ⓢ	11.5 (.453)	38.5(1.516)	69.0(2.717)	24.5 (.965)						
	7/16	12	180-12	UL Ⓢ	13.0 (.512)	38.5(1.516)	69.0(2.717)	24.5 (.965)						
	7/16	12	180-L12	UL Ⓢ	13.0 (.512)	38.5(1.516)	86.8(3.417)	39.0 (1.535)						
	1/2	14	180-14	UL Ⓢ	15.0 (.591)	38.5(1.516)	69.0(2.717)	24.5 (.965)						
	5/8	16	180-L16	UL Ⓢ	17.0 (.669)	38.5(1.516)	86.8(3.417)	39.0 (1.535)						
	5/8	16	180-16	UL Ⓢ	17.0 (.669)	38.5(1.516)	69.0(2.717)	24.5 (.965)						
	11/16	18	180-18	UL Ⓢ	19.0 (.748)	38.5(1.516)	86.8(3.417)	39.0 (1.535)						
	3/4	20	180-20	UL Ⓢ	21.0 (.827)	38.5(1.516)	86.8(3.417)	39.0 (1.535)						
	7/8	22	180-22	UL Ⓢ	23.0 (.906)	38.5(1.516)	86.8(3.417)	39.0 (1.535)						
	15/16	24	180-24	UL Ⓢ	25.0 (.984)	38.5(1.516)	86.8(3.417)	39.0 (1.535)						
	1	27	180-27	UL Ⓢ	28.0 (1.102)	38.5(1.516)	86.8(3.417)	39.0 (1.535)						

Note: 1) Products with the JIS mark Ⓢ conform to JIS C2805.
 2) Part numbers containing "S0" or "L0" do not have stud holes.
 3) Delivery lead times may vary depending on the product. Contact JST for details.

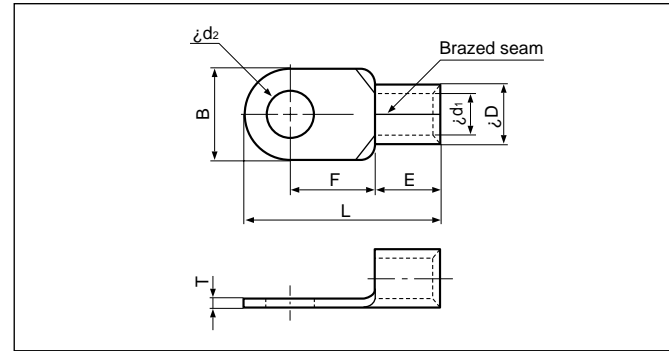
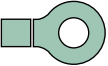

Actual

Refer to page 139 to 140 for actual size of the terminal.

Applicable Wire AWG#(mm ²)	Stud size		Part No.	Standard	Dimensions mm (in.)								Tool No.	Qty/box
	American	Metric			ød ₂	B	L	F	E	øD	ød ₁	T		
400 (192.60 to 242.27)	-	-	200-S0		-	44.0(1.732)	72.0(2.835)	24.5(.965)	31.5 (1.240)	32.7 (1.287)	24.0 (.945)	4.0 (.157)	YF-1 YET-300-1 E-4 YET-300N	10
	-	-	200-LO		-	44.0(1.732)	91.0(3.583)	37.5(1.476)						
	12/16	8	200-8	UL SF	8.4 (.331)	44.0(1.732)	72.0(2.835)	24.5(.965)						
	5/16	8	200-L8	UL SF	8.4 (.331)	44.0(1.732)	91.0(3.583)	37.5(1.476)						
	3/8	9	200-9	UL SF	9.8 (.386)	44.0(1.732)	72.0(2.835)	24.5(.965)						
	3/8	10	200-10	UL SF	10.5 (.413)	44.0(1.732)	72.0(2.835)	24.5(.965)						
	3/8	10	200-L10	UL SF	10.5 (.413)	44.0(1.732)	91.0(3.583)	37.5(1.476)						
	7/16	11	200-11	UL SF	11.5 (.453)	44.0(1.732)	72.0(2.835)	24.5(.965)						
	7/16	12	200-12	UL SF	13.0 (.512)	44.0(1.732)	72.0(2.835)	24.5(.965)						
	7/16	12	R200-12	UL SF	13.0 (.512)	44.0(1.732)	78.0(3.071)	24.5(.965)						
	7/16	12	200-L12	UL SF	13.0 (.512)	44.0(1.732)	91.0(3.583)	37.5(1.476)						
	1/2	14	200-14	UL SF	15.0 (.591)	44.0(1.732)	72.0(2.835)	24.5(.965)						
	1/2	14	R200-14	UL SF	15.0 (.591)	44.0(1.732)	78.0(3.071)	24.5(.965)						
	5/8	16	200-16	UL SF	17.0 (.669)	44.0(1.732)	72.0(2.835)	24.5(.965)						
	5/8	16	R200-16	UL SF	17.0 (.669)	44.0(1.732)	78.0(3.071)	24.5(.965)						
	5/8	16	200-L16	UL SF	17.0 (.669)	44.0(1.732)	91.0(3.583)	37.5(1.476)						
	11/16	18	R200-18	UL SF	19.0 (.748)	44.0(1.732)	91.0(3.583)	37.5(1.476)						
	3/4	20	R200-20	UL SF	21.0 (.827)	44.0(1.732)	91.0(3.583)	37.5(1.476)						
7/8	22	R200-22	UL SF	23.0 (.906)	44.0(1.732)	91.0(3.583)	37.5(1.476)							
15/16	24	R200-24	UL SF	25.0 (.984)	44.0(1.732)	91.0(3.583)	37.5(1.476)							
1	27	R200-27	UL SF	28.0 (1.102)	44.0(1.732)	91.0(3.583)	37.5(1.476)							
600/650 (242.27 to 325)	-	-	325-S0		-	50.5(1.988)	88.0(3.465)	33.5(1.319)	35.5 (1.398)	37.6 (1.480)	28.0 (1.102)	4.5 (.177)	YF-1 YET-300-1 E-4 YET-300N	5
	-	-	325-LO		-	50.5(1.988)	105.7(4.161)	45.0(1.772)						
	12/16	8	325-8	UL SF	8.4 (.331)	50.5(1.988)	88.0(3.465)	33.5(1.319)						
	5/16	8	325-L8	UL SF	8.4 (.331)	50.5(1.988)	105.7(4.161)	45.0(1.772)						
	3/8	10	325-10	UL SF	10.5 (.413)	50.5(1.988)	88.0(3.465)	33.5(1.319)						
	3/8	10	325-L10	UL SF	10.5 (.413)	50.5(1.988)	105.7(4.161)	45.0(1.772)						
	7/16	11	325-11	UL SF	11.5 (.453)	50.5(1.988)	88.0(3.465)	33.5(1.319)						
	7/16	12	325-12	UL SF	13.0 (.512)	50.5(1.988)	88.0(3.465)	33.5(1.319)						
	7/16	12	325-L12	UL SF	13.0 (.512)	50.5(1.988)	105.7(4.161)	45.0(1.772)						
	1/2	14	325-14	UL SF	15.0 (.591)	50.5(1.988)	88.0(3.465)	33.5(1.319)						
	5/8	16	325-16	UL SF	17.0 (.669)	50.5(1.988)	88.0(3.465)	33.5(1.319)						
	5/8	16	R325-16	UL SF	17.0 (.669)	50.5(1.988)	94.2(3.709)	33.5(1.319)						
	5/8	16	325-L16	UL SF	17.0 (.669)	50.5(1.988)	105.7(4.161)	45.0(1.772)						
	11/16	18	325-M18	UL SF	19.0 (.748)	50.5(1.988)	94.2(3.709)	33.5(1.319)						
	11/16	18	R325-18	UL SF	19.0 (.748)	50.5(1.988)	105.7(4.161)	45.0(1.772)						
	3/4	20	R325-20	UL SF	21.0 (.827)	50.5(1.988)	105.7(4.161)	45.0(1.772)						
	7/8	22	R325-22	UL SF	23.0 (.906)	50.5(1.988)	105.7(4.161)	45.0(1.772)						
	15/16	24	R325-24	UL SF	25.0 (.984)	50.5(1.988)	105.7(4.161)	45.0(1.772)						
1	27	R325-27	UL SF	28.0 (1.102)	50.5(1.988)	105.7(4.161)	45.0(1.772)							

Note: 1) Products with the JIS mark  conform to JIS C2805.
 2) Part numbers containing "S0" or "LO" do not have stud holes.
 3) Delivery lead times may vary depending on the product. Contact JST for details.