

- EXR series capacitors are ideal for use in switching power supplies.
- Other High Frequency Applications.
- **Low Impedance** and long life.

**Characteristics**

<b>Voltage Range</b>	6.3 to 100 VDC				160 to 450 VDC				
<b>Capacitance Range</b>	0.47 to 15000uF				0.47 to 470uF				
<b>Temperature Range</b>	-40 to +105°C				-25 to +105°C				
<b>Leakage Current</b>	I ≤ 0.01CV or 2uA, whichever is greater 3 minutes after Rated Voltage applied				I ≤ 0.03CV or 3uA, whichever is greater 3 minutes after Rated Voltage applied				
<b>Capacitance Tolerance</b>	±20% at 120Hz, 20°C								
<b>Dissipation Factor</b>	Working Voltage (V)	6.3	10	16	25	35	50	63	100
	tan δ (%) max	22	19	16	14	12	10	9	8
	Working Voltage (V)	160	200	250	350	400	450		
	tan δ (%) max	12	12	12	15	15	17		
<b>Low temperature Characteristics (120Hz)</b>	For capacitance > 1000uF, add 0.02 for every 1000uF.(at 20°C, 120Hz)								
	Working Voltage (V)	6.3	10	16	25	35	50	63	100
	Z-25°C/Z 20°C	4	3	3	3	3	3	2	2
	Z-40°C/Z 20°C	8	6	4	3	3	3	3	3
	Working Voltage (V)	160	200	250	350	400	450		
	Z-25°C/Z 20°C	2	2	3	5	5	6		
Z-40°C/Z 20°C	3	6	6	6	6	-			
<b>Load life :</b>	After the rated voltage with ripple current has been applied for at 105°C				Capacitance change		Within ±20% of initial value		
	(160V~450V : 2000HRS)				D.F. tanδ		200% or less of initial specified value		
					Leakage current		Less than initial specified value		
<b>Shelf life (at 105°C)</b>		After 1000 hrs no load: test the leakage current, capacitance and tan δ are same as load life value.							

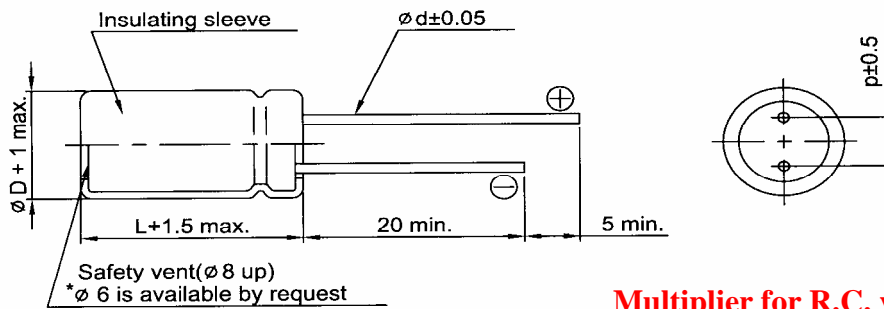

**Multiplier for R.C. vs Temperature**

Temp.(°C)	45	60	70	85	95	105
Multiplier	2.10	1.90	1.65	1.40	1.25	1.00

**Drawing**

Dφ	5	6.3	8	10	13	16	18
p	2.0	2.5	3.5	5.0	5.0	7.5	7.5
dφ	0.5	0.5	0.5	0.6	0.6	0.8	0.8

**Ripple Current Coefficients**

Frequency (Hz)	60	120	400	1K	10K	50K - 100K
<b>Cap.(uF) / Hz</b>	<b>Multiplier</b>					
Cap. ≤ 10	0.47	0.59	0.76	0.85	0.97	1
10 < Cap. ≤ 100	0.52	0.62	0.80	0.89	0.97	1
100 < Cap. ≤ 1000	0.58	0.72	0.84	0.90	0.98	1
1000 < Cap.	0.63	0.78	0.87	0.91	0.98	1

**Dimensions, Maximum Permissible Ripple Current & Impedance**

WV (SV)	6.3 (8)			10 (13)			16 (20)			25 (32)			
	Spec. uF	DφxL(mm)	Impedance (Ω)max 20°C 100KHZ	Ripple Current mA(rms) 105°C 100KHz	DφxL(mm)	Impedance (Ω)max 20°C 100KHZ	Ripple Current mA (rms) 105°C 100KHz	DφxL(mm)	Impedance (Ω)max 20°C 100KHZ	Ripple Current mA(rms) 105°C 100KHz	DφxL(mm)	Impedance (Ω)max 20°C 100KHZ	Ripple Current mA(rms) 105°C 100KHz
<b>10</b>													5x11
<b>22</b>								5x11	2.60	100	5x11	1.95	115
<b>33</b>								5x11	2.00	114	5x11	1.42	155
<b>47</b>								5x11	1.10	155	5x11	1.10	155
<b>68</b>								5x11	0.69	195	6.3x11	0.65	230
<b>100</b>				5x11	0.80	180	6.3x11	0.50	265	6.3x11	0.35	370	
<b>150</b>				6x11	0.61	240	8x12	0.41	370	8x12	0.31	390	
<b>220</b>	6.3x11	0.65	285	6.3X11	0.35	295	8x12	0.25	450	8x12	0.15	555	
<b>330</b>	8x12	0.42	390	8x12	0.27	460	8x12	0.15	590	8x14	0.12	700	
<b>470</b>	8x12	0.25	450	8x12	0.15	555	10x12.5	0.12	750	10x16	0.076	1010	
<b>680</b>	8x14	0.21	520	8x14	0.10	805	10x16	0.080	850	10x21	0.065	1220	
<b>1000</b>	8x12 10x12.5	0.17 0.10	555 750	10x12.5 10x21	0.080 0.076	805 1040	10x21	0.068	1200	13x21	0.045	1650	
<b>1500</b>	8x16 10x16	0.14 0.08	830 940	10x16 10x21	0.070 0.062	1000 1260	13x21	0.045	1575	13x26	0.038	1960	
<b>2200</b>	10x21	0.068	1050	10x21	0.052	1220	13x21	0.039	1900	16x26	0.036	2100	
<b>3300</b>	10x21 13x21	0.052 0.060	1220 1650	13x21	0.039	1660	16x26	0.030	1950	16x31	0.026	2680	
<b>4700</b>	13x21	0.039	1660	13x26	0.030	1950	16x31	0.022	2410	18x36	0.018	2960	
<b>6800</b>	16x26	0.030	2450	16x26	0.022	2150	16x36	0.018	2400	18X41	0.015	3550	
<b>10000</b>	16x31	0.022	2650	16x31	0.018	2400	18x36	0.015	2800				
<b>15000</b>	18x36	0.020	2950										

WV (SV)	35 (44)			50 (63)			63 (79)			100 (125)		
Spec. uF	DφxL(mm)	Impedance (Ω)max	Ripple Current mA(rms)	DφxL(mm)	Impedance (Ω)max	Ripple Current mA(rms)	DφxL(mm)	Impedance (Ω)max	Ripple Current mA(rms)	DφxL(mm)	Impedance (Ω)max	Ripple Current mA(rms)
		20°C	105°C		20°C	105°C		20°C	105°C		20°C	105°C
4.7				5x11	2.00	90	5x11	2.00	65	5x11	2.40	80
10				5x11	1.82	120	5x11	1.75	110	6.3x11	1.77	130
22				6.3x11	1.25	150	6.3x11	0.80	240	8x12	0.85	220
33	5x11	1.21	180	6.3x11	0.80	250	6.3x11	0.61	270	10x16	0.48	293
47	6.3x11	0.80	250	6.3x11	0.65	290	8x12	0.56	300	10x16	0.37	382
68	6.3x11	0.64	280	8x12	0.33	375	10x12.5	0.21	480	10x21	0.28	501
100	8x12	0.25	450	10x12.5	0.17	480	10x16	0.14	530	13x21	0.18	714
150	8x12	0.191	510	10x12.5	0.132	560	10x16	0.11	600	13x21	0.174	780
220	10x16	0.114	750	10x16	0.096	630	10x21	0.08	710	16x26	0.10	1282
330	10x16	0.079	1050	10x21	0.078	960	13x21	0.055	1250	16x31	0.09	1563
470	10x21	0.065	1200	13x21	0.055	1400	13x26	0.053	1620	18x32	0.076	1907
680	13x21	0.056	1570	13x26	0.044	1830	16x26	0.043	2252	18x36	0.062	2387
1000	13x26	0.042	1900	16x26	0.036	2100	16x31	0.049	2988	18x41	0.060	3100
1500	16x26	0.026	2490	16x31	0.034	2370	18x36	0.031	3100			
2200	16x31	0.022	2550	18x36	0.032	3070	18x41	0.024	3600			
3300	16x36	0.016	2650	18x41	0.025	3100						
4700	18x41	0.010	3000									

WV (SV)	160 (200)			200 (250)			250 (300)			350 (400)		
Spec. uF	DφxL(mm)	Impedance (Ω)max	Ripple Current mA(rms)	DφxL(mm)	Impedance (Ω)max	Ripple Current mA(rms)	DφxL(mm)	Impedance (Ω)max	Ripple Current mA(rms)	DφxL(mm)	Impedance (Ω)max	Ripple Current mA(rms)
		20°C	105°C		20°C	105°C		20°C	105°C		20°C	105°C
1	6.3x11	7.85	45	6.3x11	7.76	45	6.3x11	6.54	50	8x12	6.35	58
2.2	6.3x11	5.21	55	6.3x11	5.18	55	8x12	4.12	72	10x12.5	4.02	86
3.3	8x12	4.31	70	8x12	4.25	71	8x12	3.85	75	10x16	3.52	100
4.7	8x12	4.16	72	10x12.5	4.12	85	10x12.5	2.95	100	10x21	2.77	130
10	10x16	2.69	120	10x16	2.02	132	10x16	1.40	160	13x21	1.35	200
22	10x21	1.30	205	10x21	1.20	205	10x21	1.30	185	13x21	1.22	220
33	13x21	1.10	260	13x21	0.62	330	13x21	0.90	260	13x26	0.86	290
47	13x21	0.91	320	13x26	0.51	400	13x26	0.45	405	16x31	0.62	430
68	13x26	0.56	410	16x26	0.35	540	16x26	0.38	490	16x36	0.56	475
100	16x26	0.47	500	16x31	0.17	820	16x31	0.25	675	18x36	0.55	513
220	16x36	0.19	820	18x41	0.14	1080	18x41	0.20	910			
330	18x41	0.16	1000									

WV (SV)	400 (450)			450 (500)		
	Spec. DφxL(mm)	Impedance (Ω)max 20°C 100KHZ	Ripple Current mA(rms)	DφxL(mm)	Impedance (Ω)max 20°C 100KHZ	Ripple Current mA(rms)
			105°C 100KHZ			105°C 100KHZ
uF						
<b>1</b>	8x12	16.5	36	10x12.5	17.35	41
<b>2.2</b>	10x12.5	8.58	56	10x16	10.25	60
<b>3.3</b>	10x16	5.01	86	10x21	5.65	89
<b>4.7</b>	10x21	4.82	96	13x21	5.01	105
<b>10</b>	13x21	3.32	135	13x26	3.78	140
<b>22</b>	13x26	2.65	167	13x26	2.80	160
<b>33</b>	16x26	1.21	277	16x26	2.20	205
<b>47</b>	16x31	0.92	350	16x36	1.02	352
<b>68</b>	18x32	0.75	416	18x36	0.78	430
<b>100</b>	18x41	0.52	560			